



# Jeep JK Big Brake Kit

www.teraflex.com

Kit #4303400– Jeep Standard

Rotors Kit

#4303420– Jeep Slotted

Rotors

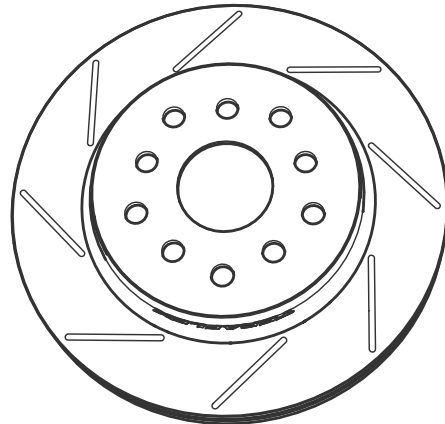
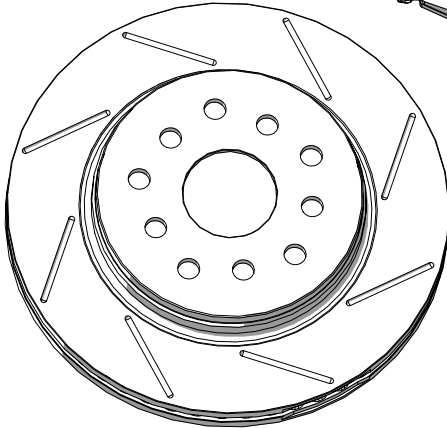
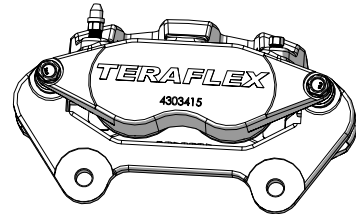
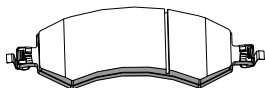
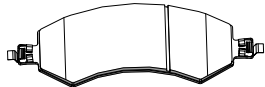
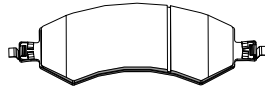
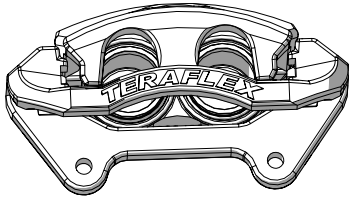

## Important Notes:

Prior to beginning this or any installation read these instructions to familiarize yourself with the required steps and evaluate if you are experienced and capable to personally perform these modifications. A factory service manual should be used in conjunction with these installation instructions.

Refer to the parts list to ensure that all necessary components and hardware has been included. If any parts are missing please contact your local TeraFlex dealer for assistance.

## Tools needed:

- This installation guide
- Basic mechanics tool set

Scan to  
watch the  
video!



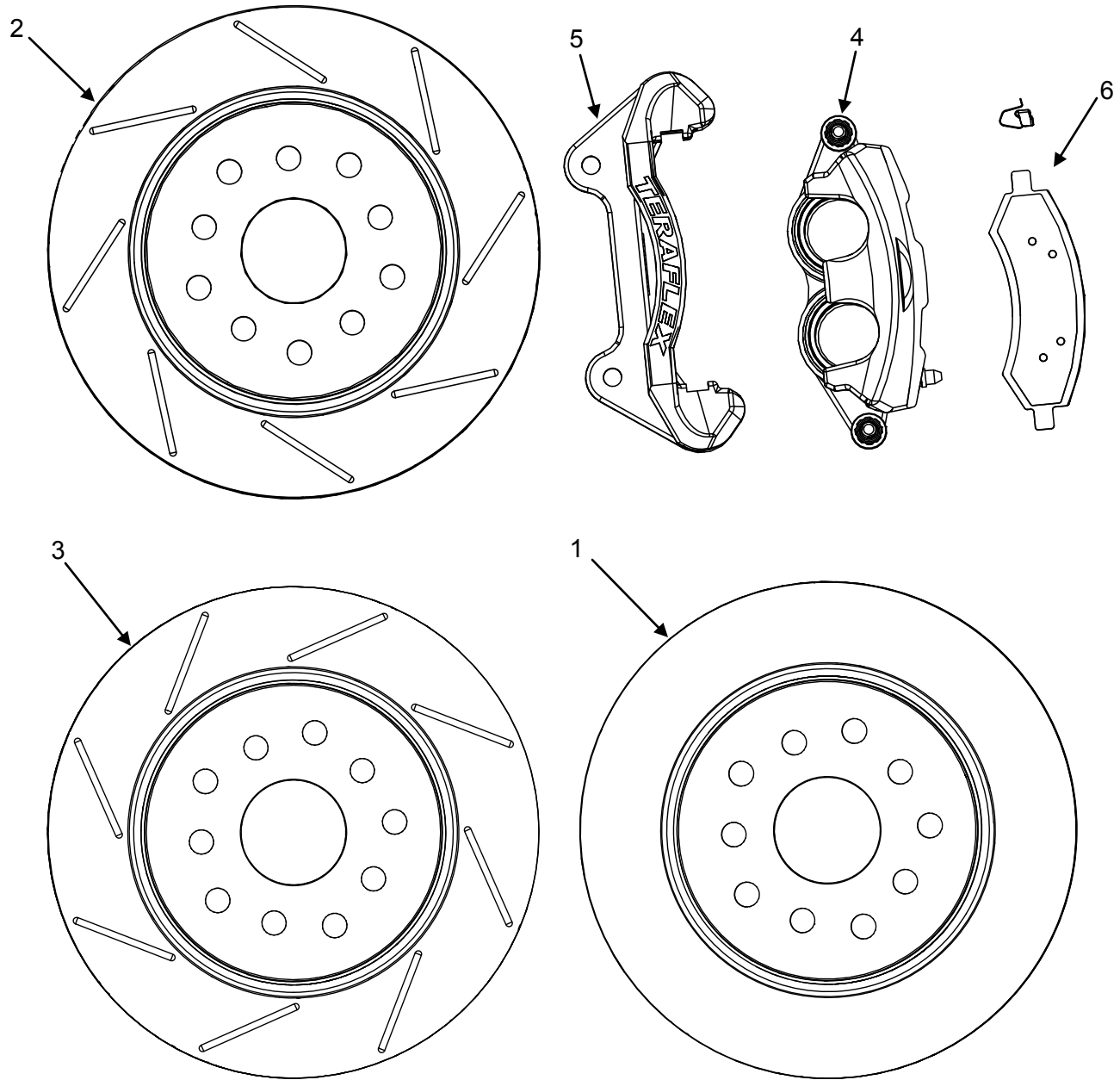

Parts List			
Item Number	Part Number	Description	Quantity
1	4303410	JK Front Plain Rotor 13.3" Big Brake (Kit #4303400 Only)	2
2	4303412	JK Front Slotted Driver Rotor 13.3" Big Brake (Kit #4303420 Only)	1
3	4303411	JK Front Slotted Passenger Rotor 13.3" Big Brake (Kit #4303420 Only)	1
4	4303415	JK Front Big Brake Caliper	2
5	4303405	JK Front Big Brake Anchor Bracket	2
6	303430	Big Brake JK Front Brake Pads and Clips	2

Safely raise and support the vehicle. See the factory service manual for safe support locations. Remove the front tires.

**Hint: Before removing the caliper bolts, loosen the 15mm banjo bolt that secures the brake line. Then snug it back down enough so that it wont leak. This will make removal and installation of the brake line easier.**

1

Remove the caliper and anchor bracket with a 21mm. Support the caliper from the frame, do not allow the caliper to hang from the brake hose. A plastic zip tie works well.

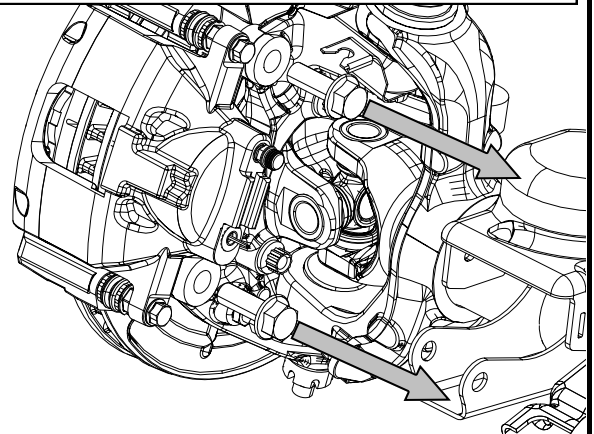

2

Remove the factory rotor. If the factory retainers are still present, break the retainers and discard.

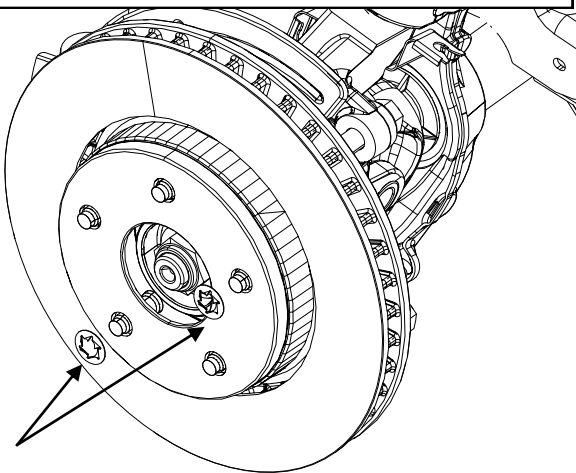

3

Install the new rotor. If slotted rotors are being used, the slots should be oriented as shown, with opposite side mirrored.

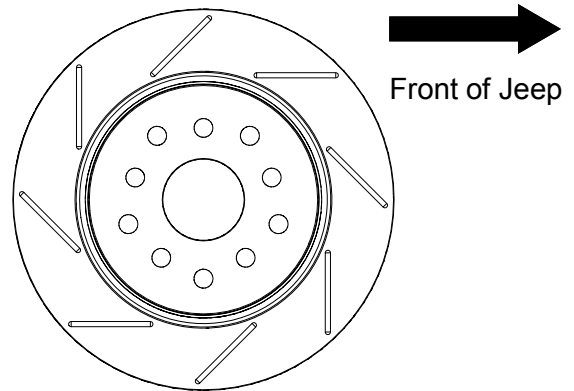

Front Right Brake Rotor

4

Install the anchor bracket/caliper assembly with pads onto the knuckle using the factory 21mm bolts.

Torque to **120 ft-lbs (163 Nm)**

**Note: the bleeder valve should be in the higher position.**

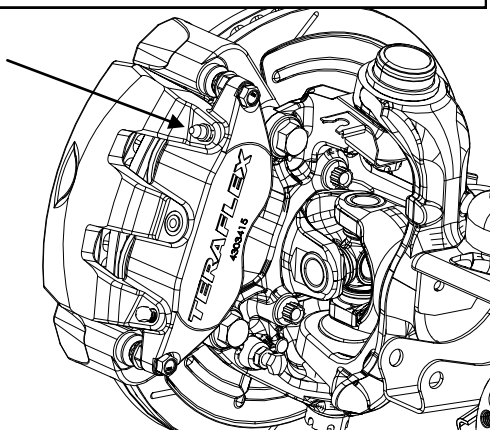

5

Remove one of the pin bolts from the TeraFlex caliper. Use a 14mm for the bolt and a 17mm to hold the pin.

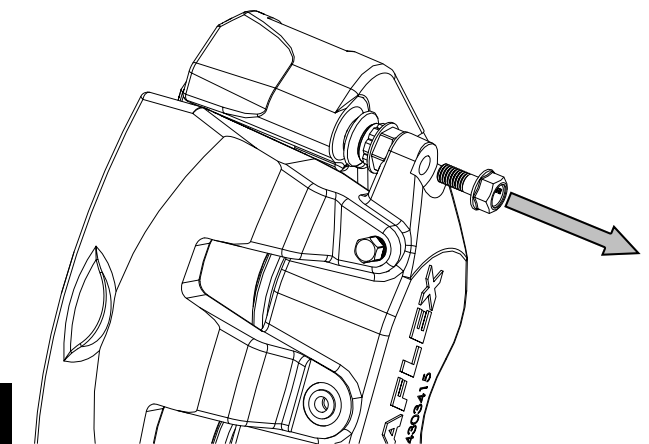

6

Swing the caliper away from the anchor bracket. Peel the adhesive backing off the pads. Also apply brake grease to anchor bracket where brake pad makes contact (1).

**Caution: Do not allow grease to get on the rotor or the pad to rotor contact points.**

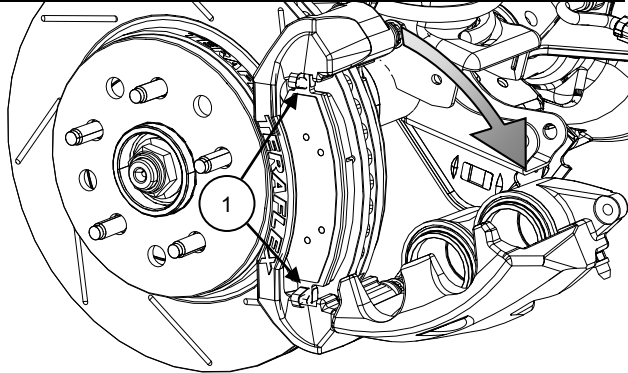

7

Swing the new caliper back into position and reinstall the pin bolt. Torque to **26 ft-lbs (35 Nm)**

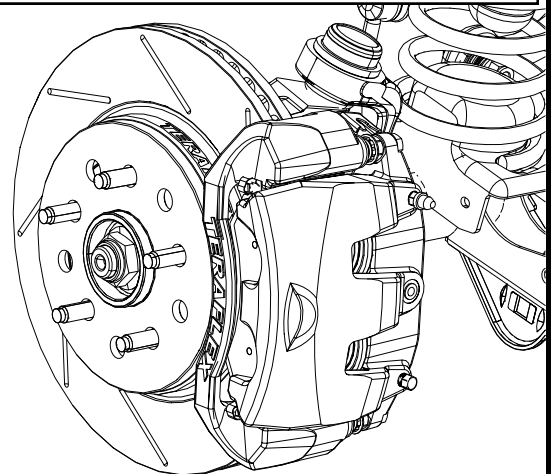

8

Remove the brake line from the factory caliper by removing the banjo bolt with a 15mm. Hint: Try to have your new copper washers ready so that this and the next step goes quick and easy, minimizing the mess.

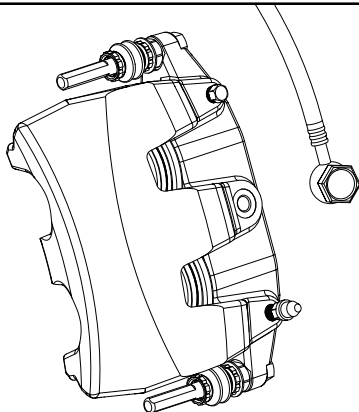

9

Install the brake line onto the new caliper using the factory banjo bolt and 2 new copper washers. Torque bolt to **23 ft-lbs (31 Nm)**  
**Note: Position of copper washers in relation to brake line**

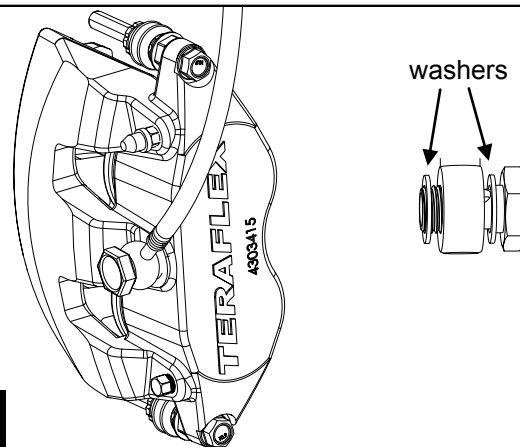

10

Repeat process on opposite side. Bleed brakes according to standard procedure.

11

### Suggested Pad and Rotor Break-in Procedure:

**Note: It may initially seem that excessive brake pedal travel is required to stop the vehicle. This is due to new pads and new rotors that have not yet been "seated". This condition will improve during break-in. We recommend performing this procedure where no pedestrian or vehicle traffic is present.**

1. Brake from 30mph to 10mph ten times, allowing approximately 30 seconds between each stop for cooling. Do not drag the brakes or stop completely during these stops. Allow the vehicles brakes to cool for 15 minutes. Do not apply the brake while stopped during cooling time.
2. Next, do 5 stops from 60mph to 15mph. Drive for 1/2 mile between stops. Then, let the brakes cool for 30 minutes.
3. The brakes should now feel significantly more effective, and break-in will self-complete during normal daily driving.

## PRODUCT INFORMATION

### MAINTENANCE INFORMATION:

It is the buyer's responsibility to have all suspension, drivetrain, steering, and other components checked for proper tightness and torque after the first 100 miles and every 3000 miles after that.

### NOTICE TO INSTALLER:

The enclosed "Warning to Driver" sticker must be installed in the vehicle in driver's view. This sticker is to act as a constant safety reminder when operating the vehicle. It is your responsibility as the equipment installer to install the provided sticker and to forward the product instructions to the vehicle's owner for review. If a "Warning to Driver" sticker or product installation guide were not included in the kit, FREE replacement stickers and instructions are available by request. It is the installer's duty to ensure a safe and controllable vehicle after the modifications have been performed.

### WARNING:

Neither the seller nor the manufacturer will be liable for any loss, damage, or injury directly or indirectly arising from the use of or inability to determine the use of these products. Before using, the user shall determine the suitability of the products for its intended use, and the user shall assume all responsibility and risk in connection therewith.

### WARNING TO DRIVER:

This vehicle has been modified to enhance off road performance and has unique handling characteristics. Use in harsh environments can cause extreme stress on the components. Vehicle should be inspected after being off road to make sure that all the components are in working order and safe to travel on the highway. All fasteners should be checked so that they are at the correct torque specifications as the vibration and stresses from off roading may cause critical fasteners to work loose. Extra care should be taken to inspect the critical components, steering, and brake systems. During each oil change components such as arms, tie rod ends, etc should be greased and checked for excessive wear. Any worn components should be replaced. When returning to the pavement always set or restore tire air pressure to the factory recommendation and connect or engage any disabled sway bar mechanisms. Because of the higher center of gravity and larger tires, this vehicle handles and reacts differently than many passenger cars, both on and off road. You must drive it safely! Extreme care should be taken to prevent vehicle rollover or loss of control, which can result in serious injury or death. Avoid sudden sharp turns or abrupt maneuvers. Generally, braking performance and capabilities are decreased when significantly larger/heavier tires are used, especially when used in combination with transfer case low-range reduction kits. Take this into consideration while driving. Do not add, alter or fabricate any factory or aftermarket parts to increase vehicle height over the intended height of the TeraFlex product purchased. Mixing component brand is not recommended. TeraFlex Inc. will not be responsible for any altered product or any improper installation or use of our products. We will be happy to answer any questions concerning the design, function, and correct use of our products. It is ultimately the buyer's responsibility to have all bolts/nuts checked for tightness after the first 100 miles and then every 3000 miles. Wheel alignment, steering system, suspension and drive line systems must be inspected by a qualified professional mechanic at least every 3000 miles.

### TERAFLEX PRODUCT WARRANTY:

TeraFlex Inc. warrants TeraFlex Suspension products to the original retail purchaser to be free of defects in material and workmanship for as long as the original purchaser owns the vehicle on which products were originally installed.

Failure to complete regular maintenance (grease every 3000 miles) on TeraFlex FlexArms will void this warranty. All other conditions of the standard TeraFlex product warranty apply.

All TeraLow products are covered by the TeraFlex two (2) year warranty to be free of defects in material and workmanship for two years from date purchased.

TeraFlex axles are covered by a 12-month warranty to be free of defects in materials and workmanship.

This warranty does not cover or include product finish, improperly installed or applied products, improperly maintained products, products or components used for racing or competition or damage due to abuse or neglect, products that fail due to the use of larger tire and wheel combinations.

All returns must be accompanied by an original invoice. It is the customer's responsibility to remove the product from the vehicle. Shipping charges are the responsibility of the customer. TeraFlex Inc. will pay the return freight if the product meets the terms of warranty.

This warranty is for the replacement or repair of defective TeraFlex products only and does not include freight charges, labor charges for removal of or installation of TeraFlex or related products or components, costs incurred due to down time of the vehicle, or lost profits due to vehicle down time.

A returned goods authorization number (RGA#) must accompany any returned products. For more information please contact a TeraFlex customer service representative.

### COPYRIGHT

©Copyright 2014. All rights reserved, TeraFlex Inc. Reproduction of this catalog and/or any of its contents without written permission is strictly prohibited.

TeraFlex® is a registered trademark of TeraFlex Inc. All trade names and logos including but not limited to TeraFlex, FlexArms, RockGuard, Monster, and LCG are protected by law and duplication of trade names and/or logos are strictly prohibited.

TeraFlex Inc. reserves the right to update, discontinue, redesign, modify finish, part number or component build parts if deemed necessary without written notice.

TeraFlex Inc., and any associated dealers are not responsible for misprints or typographical errors that may have inadvertently been made within this instruction sheet.

Jeep® and the Jeep® grill are registered trademarks of Fiat Chrysler Automobiles N.V., and have no affiliation with TeraFlex Inc.

**TERAFLEX, Inc.**  
5680 West Dannon Way  
West Jordan, Utah 84081  
Phone/801.713.3314  
Fax/801.713.2313  
[www.teraflex.com](http://www.teraflex.com)