

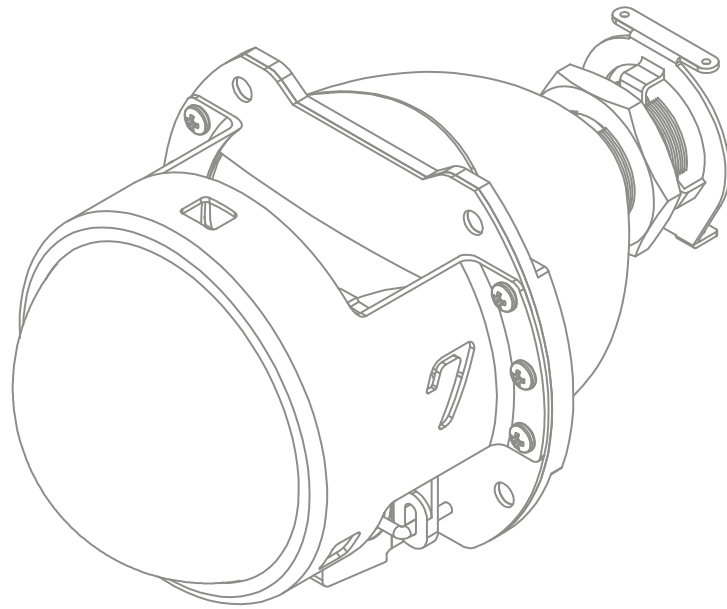

THE AUTOMOTIVE LIGHTING BENCHMARK



INSTALLATION GUIDE
SUBARU LEGACY RETROQUIK



WARNING: By reading this document, I agree it is only to be used as an educational guide. Morimoto Lighting makes no guarantee on any finished results, nor are they to be held responsible for any damage, misuse, or personal injuries. Use at your own risk. If you are unable to clearly understand and adapt the information below to your own application, professional installation is recommended.

TABLE OF CONTENTS

KIT CONTENTS	P.3
HARDWARE ASSEMBLY	P.4
PROJECTOR INSTALLATION	P.5
SYSTEM DIAGRAM	P.6
BULB INSTALLATION	P.7
HARNES INSTALLATION	P.9
BALLAST INSTALLATION	P.10
RETRORUBBER SEALANT INSTALLATION	P.10

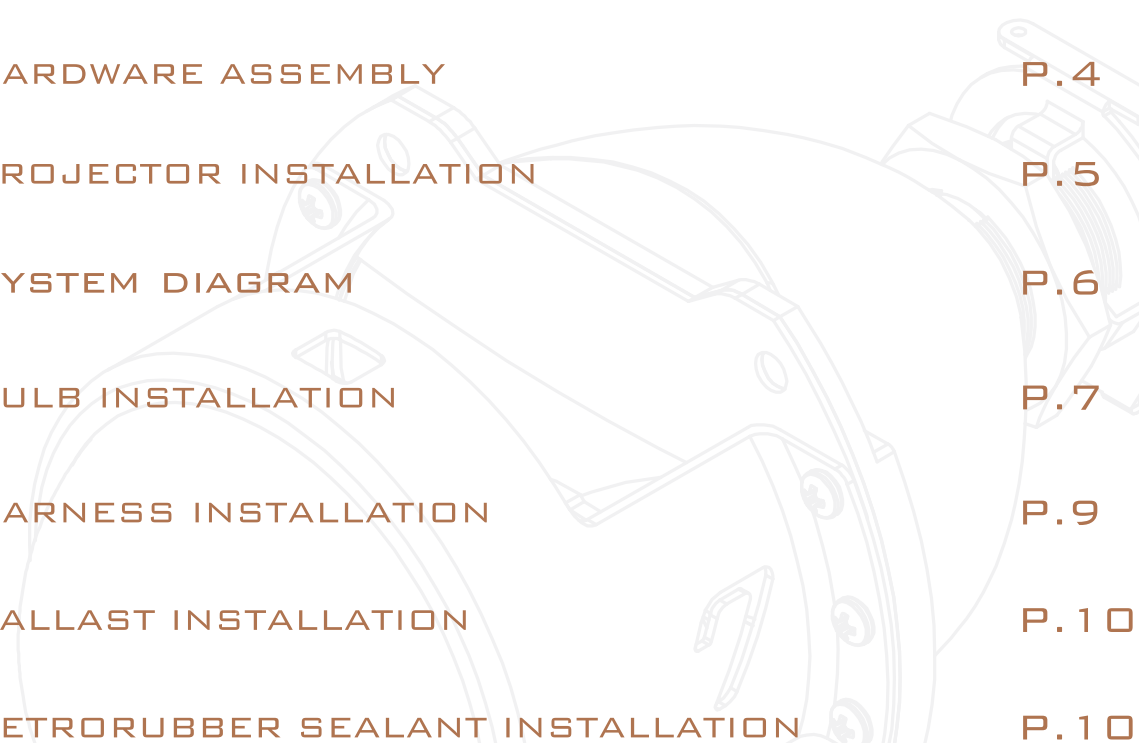

TOOLS REQUIRED

#1 PHILIPS HEAD SCREWDRIVER

#2 PHILIPS HEAD SCREWDRIVER

UTILITY SCISSORS

BROAD-NOSE PLIERS

GAS OR ELECTRIC OVEN

HEAT-RESISTANT GLOVES

STANDARD PARTS

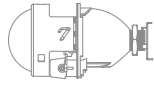

2X PROJECTORS

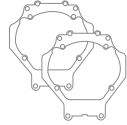

2X RQ HARDWARE / BRACKETS

OPTIONAL PARTS

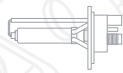

2X HID BULBS



2X BULB WIRES

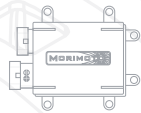

2X BALLAST COMPUTERS



2X AMP IGNITERS

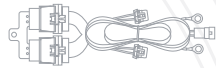

1X HD RELAY HARNESS



2X HIGH BEAM SPLITTERS



1X RETRORUBBER SEALANT

1

Remove the six #1 Philips screws holding the lens holder to the back of the projector. The six OEM screws can be discarded and are not reused.

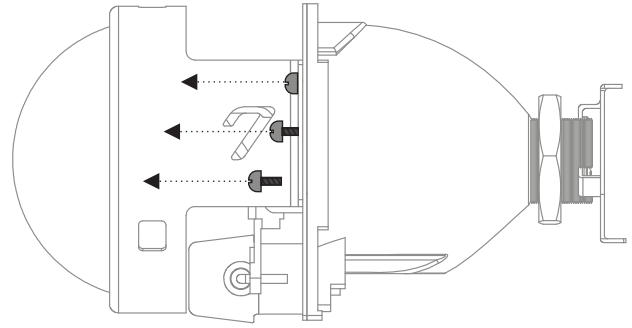

2

Fit the RetroQuik bracket in place.

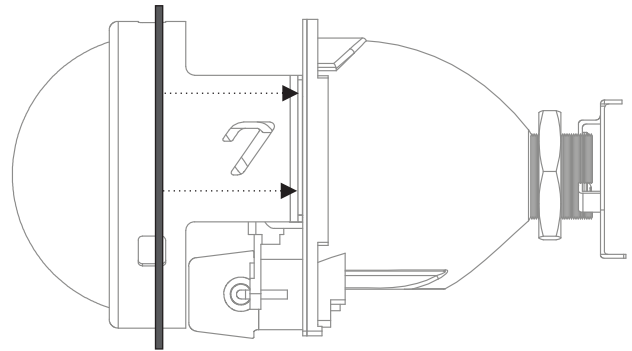

3

Install the provided six (6) longer screws into the same location as the OEM screws and snug up.

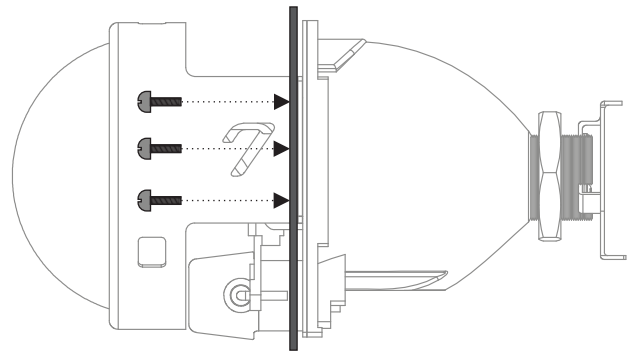

4

Insert the solenoid wiring into the solenoid's plug at the rear of the projector. Add one 9006 socket grommet per wire past the pin, then click the pins into the 9006 male connector as shown. Seat the 9006 socket grommets down into the back of the connector around the pins.

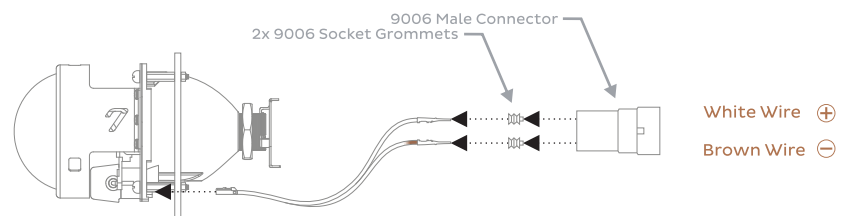

1

Once the headlight is removed from the vehicle, it must be opened to gain access to the OEM projector. We recommend this video to aid with this step:

<https://www.youtube.com/watch?v=anNOvYBj6Uo>



2

Remove the four Philips head screws that secure the OEM projector. Install the Mini H1 projector in its place, and re-install the OEM screws to retain the new projector.

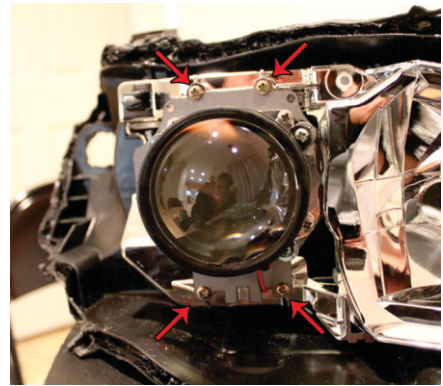

 Continue to Page 6

Side of vehicle
closer to battery

Side of vehicle
further from battery

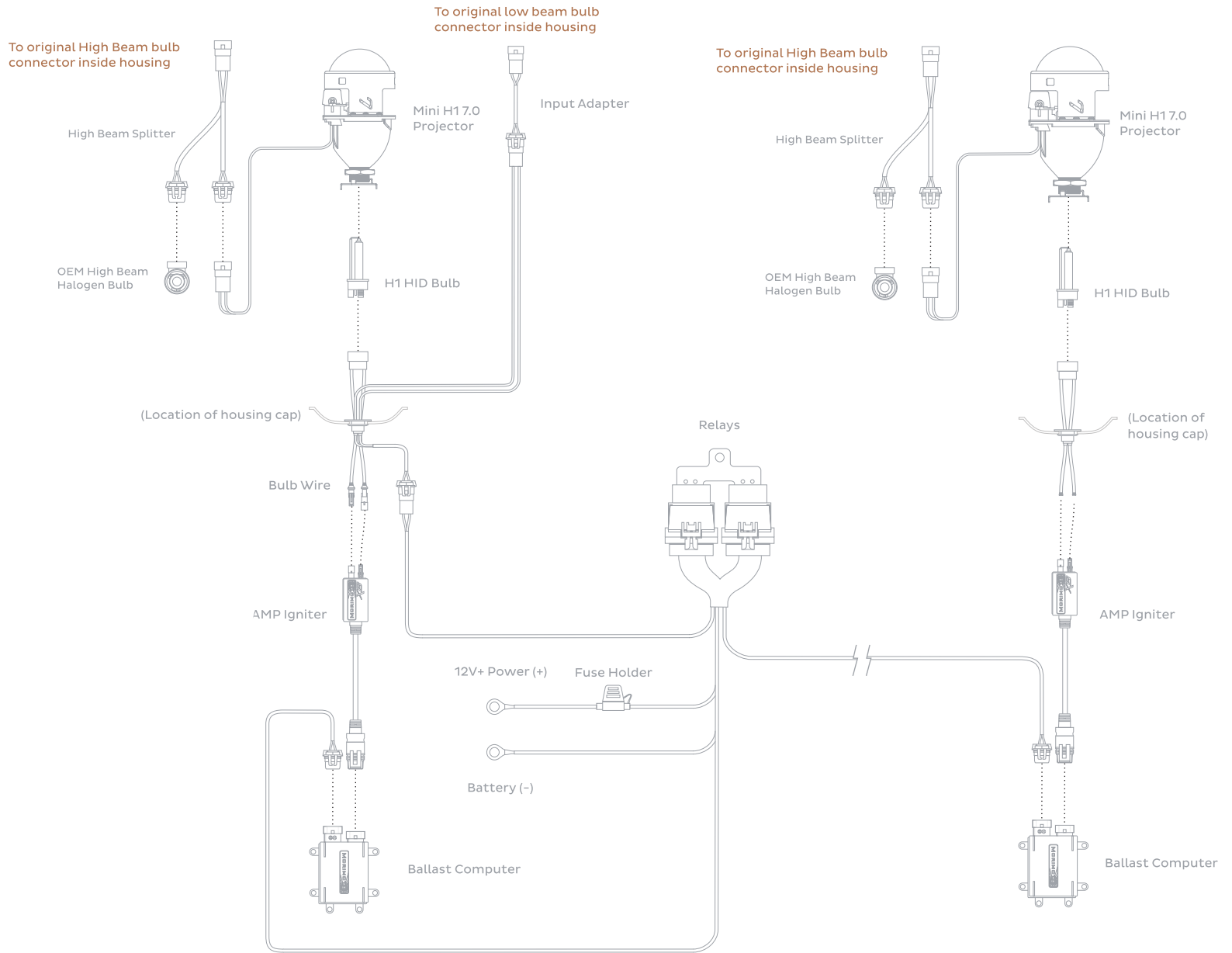

BULB INSTALLATION

1

Using an alcohol wipe, clean the glass capsule of the HID bulb.

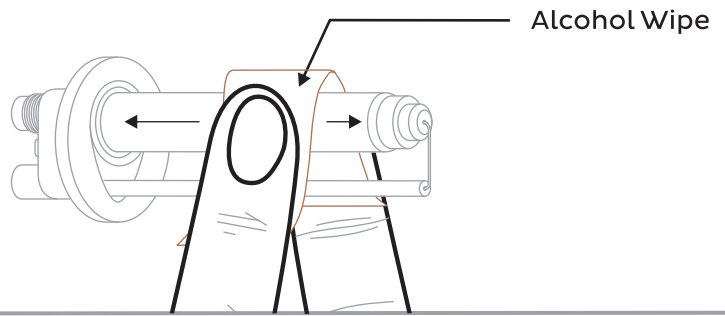

2

Insert the bulb with the ground wire at the 6 o'clock position (bottom).

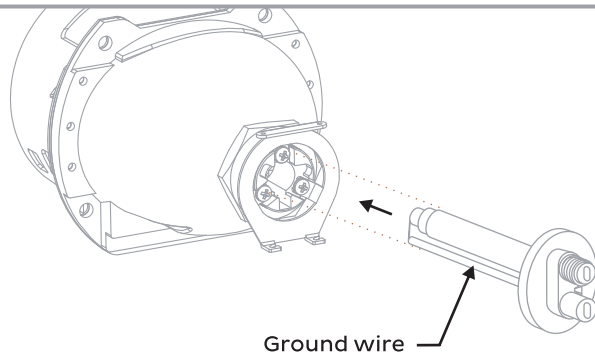

3

Insert the two ends of the bulb clip into the bulb holder.

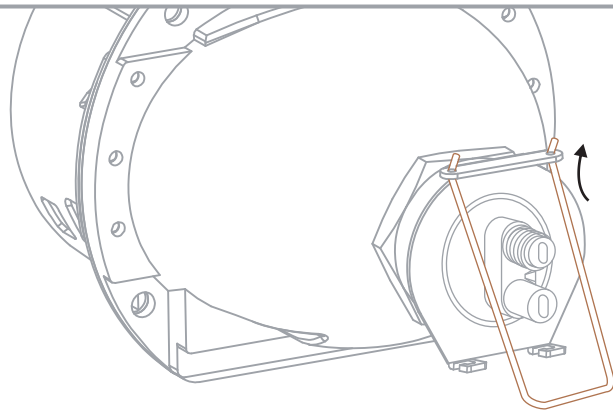

4

Clip in the bottom of the bulb clip to both hooks to properly secure bulb in the projector.

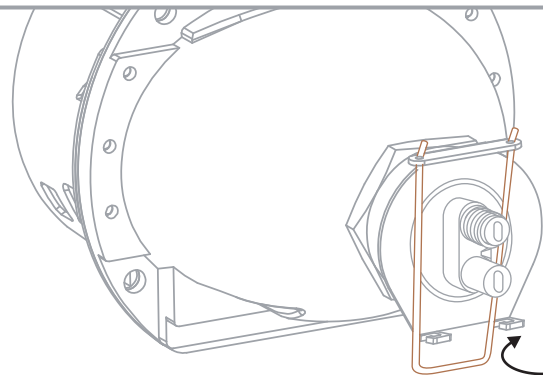

5

Click bulb wire connection onto bulb. Ensure the internal tab is fully latched.

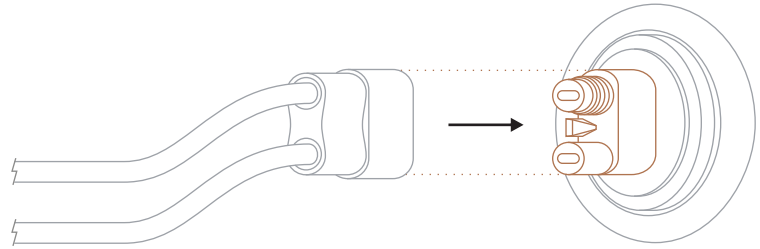

6

Click male and female AMP connectors into igniter. Ensure tabs are fully latched.

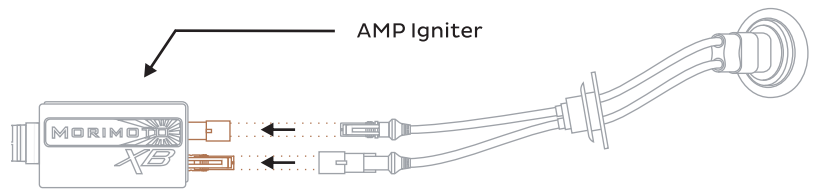

7

Inside the housing, connect the pass-through wiring into the original bulb connector. NOTE: Style may vary.

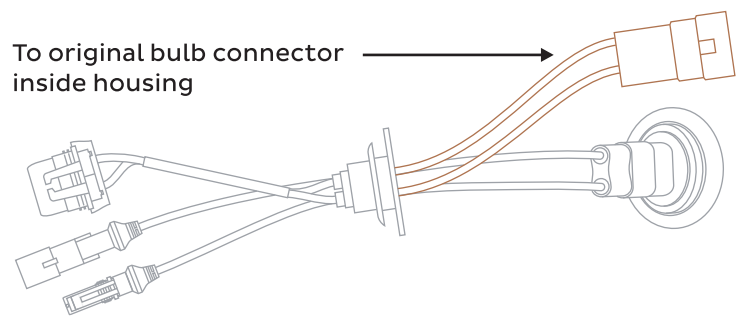

8

In the factory housing cap that covers the bulb, drill a 22mm hole using a hole saw.

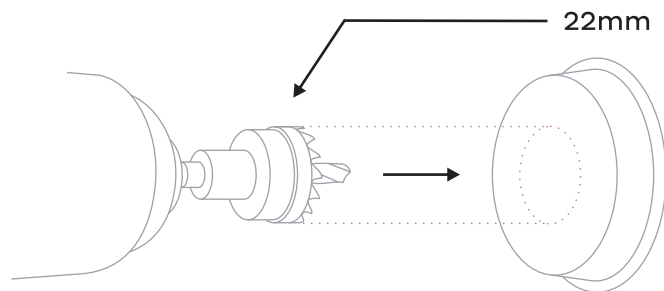

9

Re-install the factory housing cap into its original position.

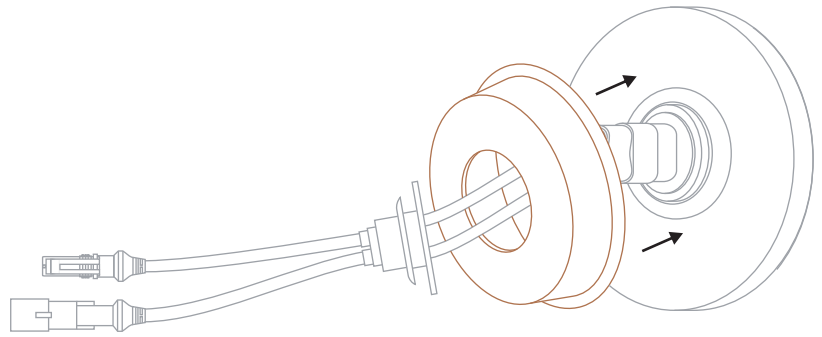

10

Fit black silicone gasket into hole in housing cap, allowing each side to fully cover the drilled hole.

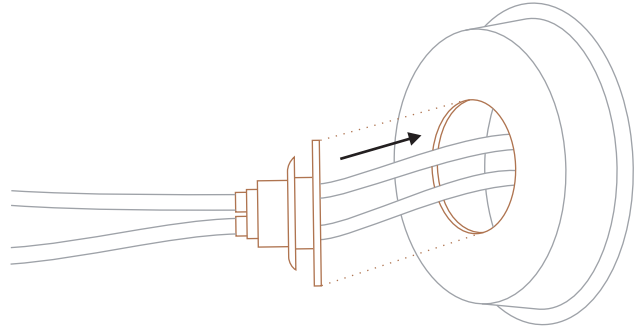

11

The last connector is the harness input. On the relay harness setup, only the side closer to the battery is needed.

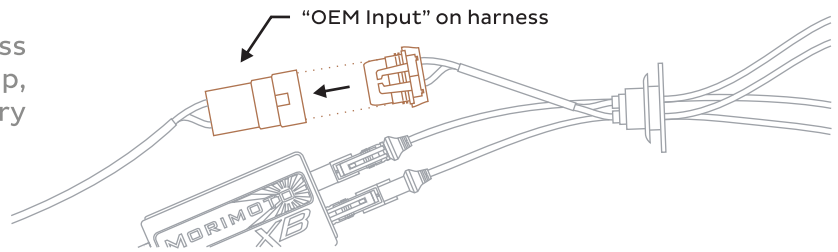

HARNESS INSTALLATION

The mounting hole is used to hang the relay(s) from and allow the wires to exit at the bottom. This minimizes the chance of water being able to enter the connector.

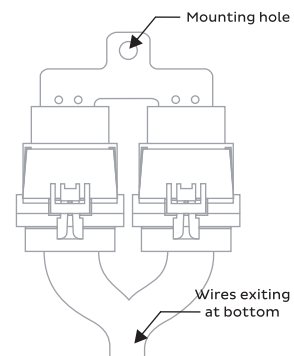

BALLAST INSTALLATION

1

Connect "Ballast Output" from harness to the ballast input and AMP igniter to ballast.

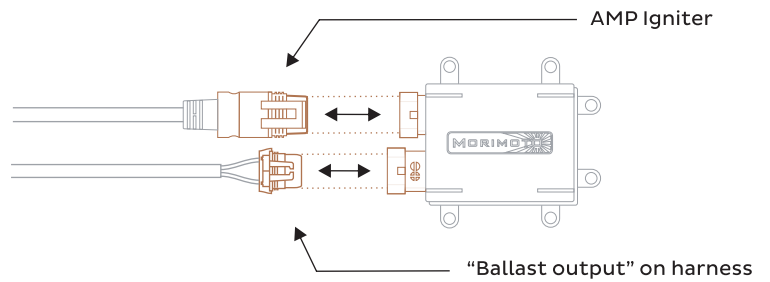

2

Listen for click of connectors to ensure they are fully seated!

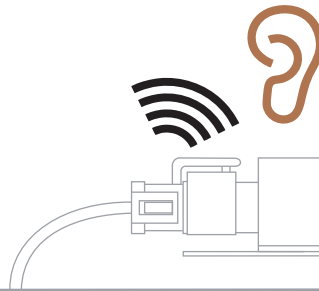

3

Do not mount ballast with connectors aimed upward!

Recommended mounting:

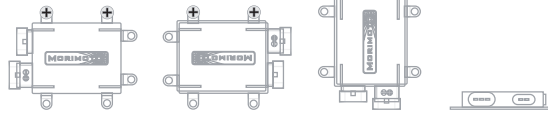

RETRORUBBER SEALANT INSTALLATION

1

Place bead of RetroRubber sealant in channel of headlight housing as shown. Fill the majority of the channel to ensure it sufficiently holds the front lens once re-installed.

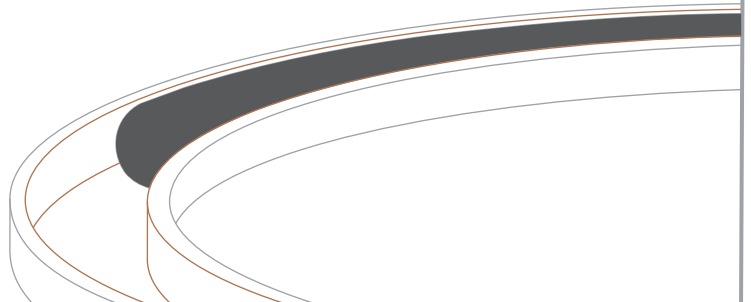

2

Use scissors to cut the Retro Rubber once the entire circumference of the housing has been filled.

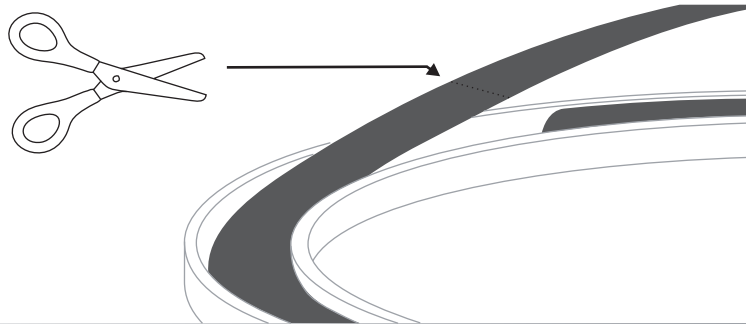

3

Re-fit the headlight lens back over the channel in the headlight housing and press gently.

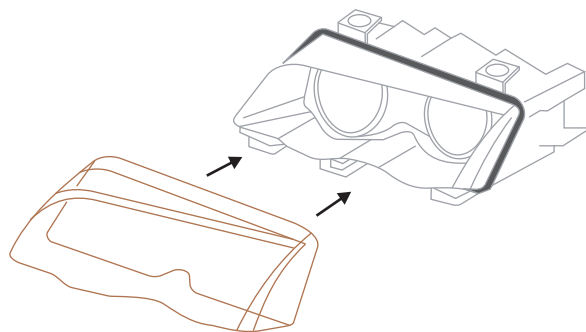

4

Place entire headlight in oven for seven (7) minutes at 270 Fahrenheit / 130 Celsius to soften the new sealant.

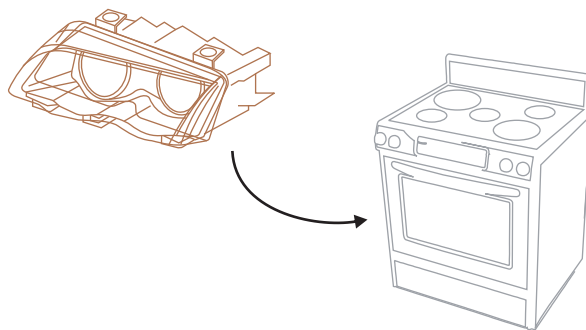

5

Using pliers, squeeze the channel back together snugly to ensure the RetroRubber creates a proper seal. Re-install OEM screws with the sealant still hot.

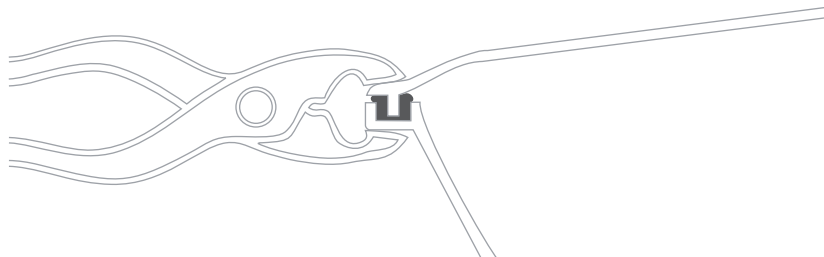

6

Allow thirty (30) minutes for headlight to sufficiently cool down prior to re-installation on car.

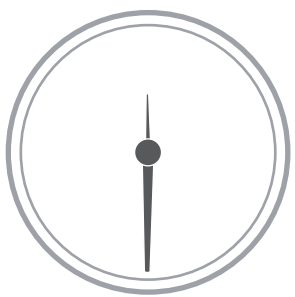

00:30:00



Installation is now complete. Make final aiming adjustments now.